

---

### STEP 1

Set the Armor-Edge® All Steel joint assembly to the correct line of the construction joint and hold in place using nail stakes through the holes in the setting brackets.

---

### STEP 2

Insert 2 x 4 x 5 inch (50 x 100 x 125 mm) wooden nailing blocks into the setting bracket behind the nail stakes. For long runs, join joint assembly at overlap using provided nylon nuts and bolts.

---

### STEP 3

Adjust the assembly to the specified elevation and hold in place with duplex nails through the nail stakes. Adjust to correct level and elevation using wedges if needed.

---

### STEP 4

If the Armor-Edge All Steel joint assembly butts up to a saw-cut contraction joint, cut through the full depth of the side that abuts the saw-cut to allow activation of the joint.

---

### STEP 5

Place and finish the first slab. The first pour must be on the side with the Diamond Dowel® pocket formers. Use internal vibration to consolidate concrete around the assembly per industry guides for embedments. Remove concrete paste from the top of the Armor-Edge steel bars during finishing.

---

### STEP 6

Insert the Diamond Dowel plate into the slot created by the pocket former. Center the corner of the plate in the middle of the label and push straight through the label into the pocket former. Do not hammer or use excessive pounding force to insert plate. Diamond Dowel plate should be inserted within 24 hours.

---

### STEP 7

Remove nail stakes, wooden nailing blocks, and wedges (if used) taking care not to disturb the form.

---

### STEP 8

Place and finish the second slab. Use internal vibration to consolidate concrete around the assembly per industry guides for embedments.

---

### STEP 9

Remove concrete paste from the top of the Armor-Edge steel bars during finishing.

---

### STEP 10

Threads of nylon nut will strip when concrete contracts.

---

### STEP 11

Fill joints as outlined in the project specification.

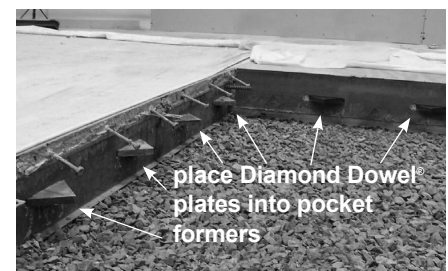
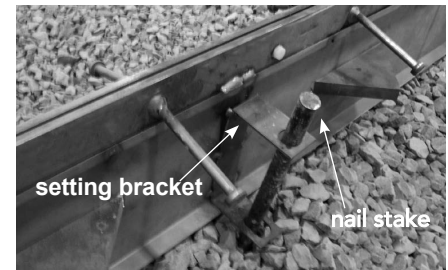

If your project involves intersections, please follow the below guides:

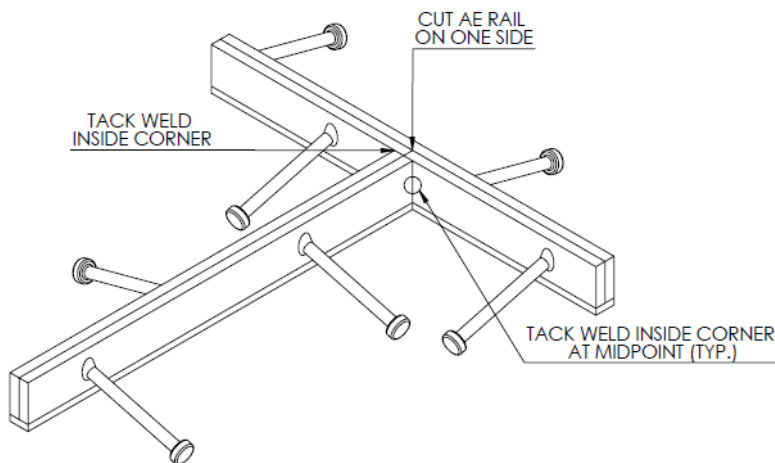
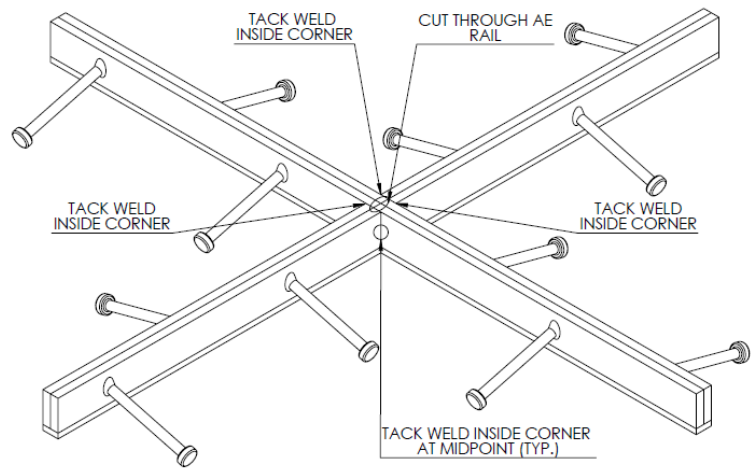
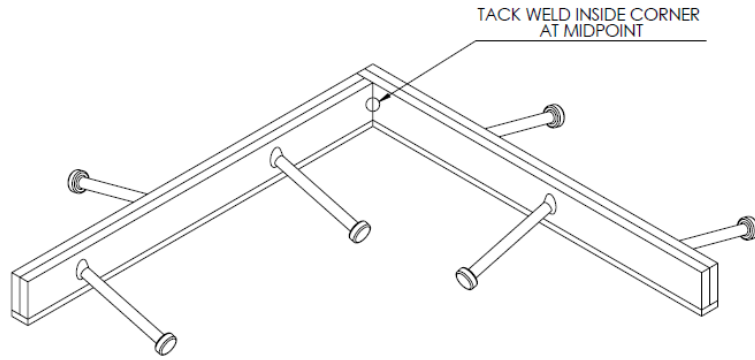

For price quotes, email inquires to [csr@pna-inc.com](mailto:csr@pna-inc.com).

To place an order, email your purchase order (PO) to [orderspna@pna-inc.com](mailto:orderspna@pna-inc.com).

To speak with a Customer Service Representative, call 1 (800) 542-0214.

©2022. PNA Construction Technologies, Inc. All rights reserved. 01/22. Products are registered trademarks of PNA Construction Technologies, Inc. and may be covered by one or more U.S., international or pending patents. Visit [www.pna-inc.com](http://www.pna-inc.com) for the list of trademarks and patents.

**PNA-2**



[www.pna-inc.com](http://www.pna-inc.com)  
©2021 Illinois Tool Works, Inc.