STEP 1

Set the Armor-Edge® All Steel joint assembly to the correct line of the construction joint and hold in place with nail stakes through the holes in the setting brackets.

STEP 2

Insert 2 x 4 x 5 inch (50 x 100 x 125 mm) wooden nailing blocks into the setting bracket behind the nail stakes. For long runs, join joint assembly at overlap using provided nylon nuts and bolts.

STEP 3

Adjust the assembly to the specified elevation and hold in place with duplex nails through the nail stakes. Adjust to correct level and elevation using wedges if needed.

STEP 4

If the Armor-Edge® All Steel joint assembly will butt up to a saw-cut contraction joint, cut through the full depth of the side of the joint assembly that abuts the saw-cut to allow activation of the joint.

STEP 5

Place Diamond Dowel® pocket formers over the Diamond Dowel® plates on the opposite side of the form to the nail stakes. Ensure pocket formers completely cover the plate that will protrude into the first placement.

STEP 6

Place and finish the first slab. Use internal vibration to consolidate concrete around the assembly per industry guides for embedments. Remove concrete paste from the top of the Armor-Edge® steel bars during finishing.

STEP 7

Remove nail stakes, wooden nailing blocks and wedges (if used) taking care not to disturb the form.

STEP 8

Place and finish the second slab. Use internal vibration to consolidate concrete around the assembly per industry guides for embedments.

STEP 9

Remove concrete paste from the top of the Armor-Edge® steel bars during finishing.

STEP 10

Threads of nylon nut will strip when concrete contracts.

STEP 11

Fill joints as outlined in the project specification.

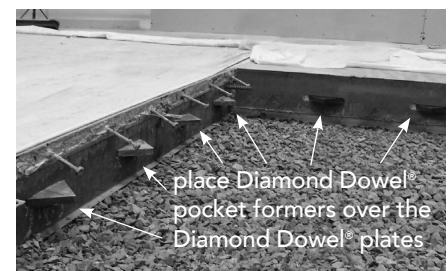
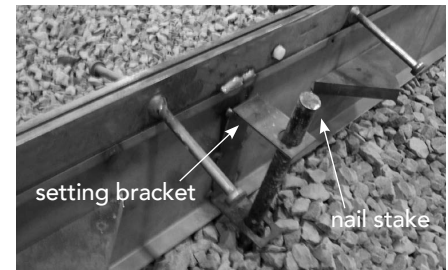

If your project involves intersections, please follow the below guides:

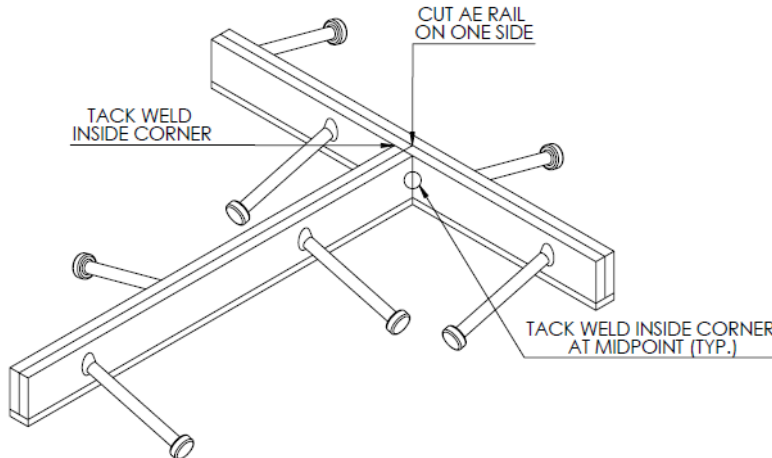
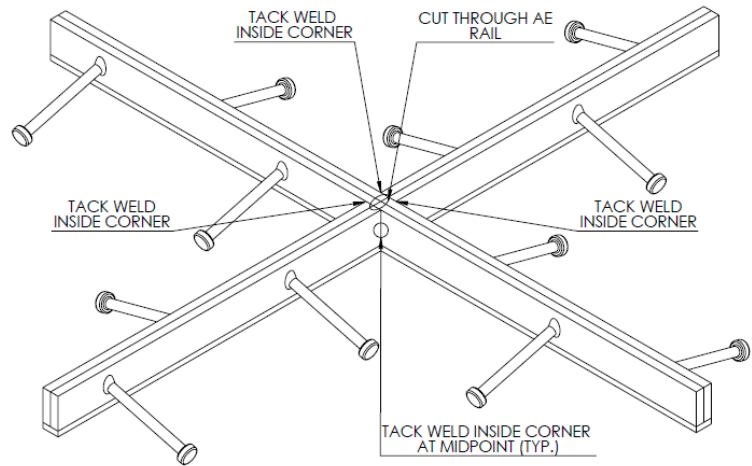
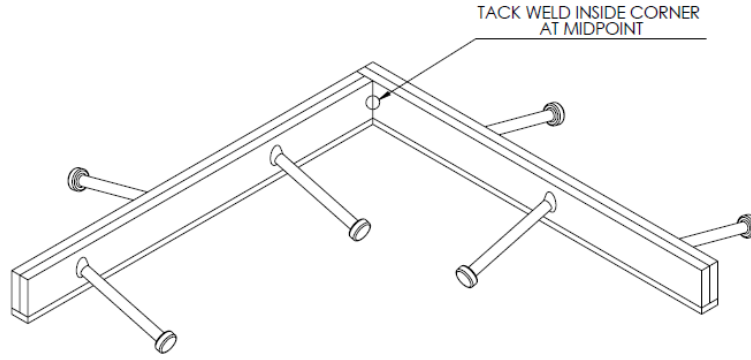

For price quotes, email inquires to csr@pna-inc.com.

To place an order, email your purchase order (PO) to orderspna@pna-inc.com.

To speak with a Customer Service Representative, call 1 (800) 542-0214.

©2022. PNA Construction Technologies, Inc. All rights reserved. 01/22. Products are registered trademarks of PNA Construction Technologies, Inc. and may be covered by one or more U.S., international or pending patents. Visit www.pna-inc.com for the list of trademarks and patents.

PNA-2



www.pna-inc.com
©2021 Illinois Tool Works, Inc.