

### STEP 1

Remove the top layer of concrete from the joint area.

### STEP 2

Place the Diamond Dowel Plate on the prepared surface. The plate should be centered on the joint line. Push the plate into the concrete until it is flush with the surface. Do not hammer or use excessive force.

### STEP 3

Remove the Diamond Dowel Plate from the concrete. The plate should be removed within two weeks of concrete placement. The hole left by the plate will be filled with concrete during the next pour.

### STEP 4

Place the second layer of concrete on top of the first layer. Use internal vibration to consolidate the concrete under the Diamond Dowel plate. The concrete should be finished to the same level as the first layer.

### STEP 5

Remove the mounting bracket from the joint assembly. Strip the bulkhead and bend the nails protruding from the pocket former so they are flush with the joint face.

### STEP 6

Insert the Diamond Dowel plate into the slot created by the Diamond Dowel pocket former. Center the corner of the plate in the middle of the label and push straight through the label into the pocket former. Do not hammer or use excessive force.

### STEP 7

Remove mounting bracket from joint assembly. Strip bulkhead and bend nails protruding from pocket former so they are flush with the joint face.

### STEP 8

Insert the Diamond Dowel plate into slot created by Diamond Dowel pocket former. Center the corner of the plate in the middle of the label and push straight through the label into the pocket former. Do not hammer or use excessive pounding force to insert Diamond Dowel plate. Diamond Dowel plate should be inserted within two weeks of concrete placement.

### STEP 9

Place and finish second slab. Use internal vibration to consolidate concrete under Diamond Dowel plate per industry guides for embedments.

### STEP 10

Remove concrete paste from the top of the Armor-Edge steel bars during finishing. Threads of nylon nut will strip when concrete contracts.

### STEP 11

Fill joints as outlined in the project specification.

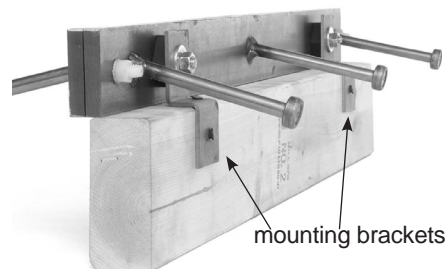

If your project involves intersections, please follow the below guides:

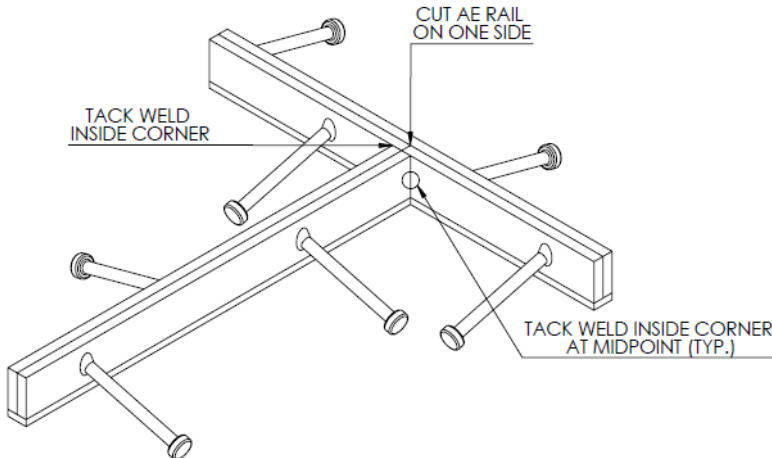
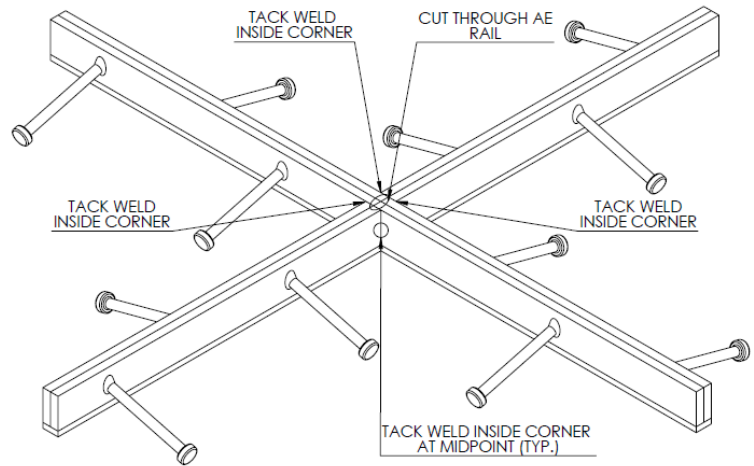
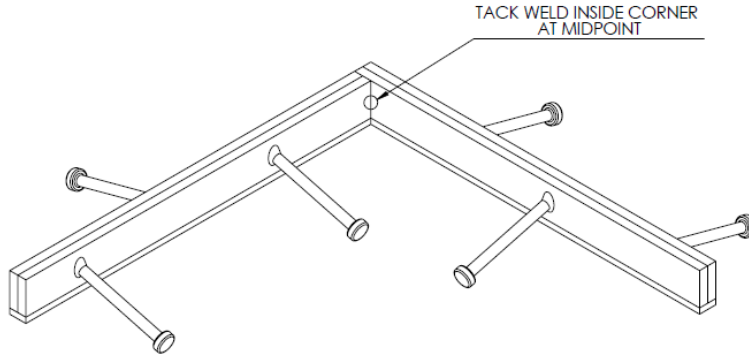

©2024. PNA Construction Technologies, Inc. All rights reserved. 04/24 Products are registered trademarks of PNA Construction Technologies, Inc. and may be covered by one or more U.S., international or pending patents. Visit [www.pna-inc.com](http://www.pna-inc.com) for the list of trademarks and patents.

**PNA-2**